

Please read and save this Repair Parts Manual. Read this manual and the General Operating Instructions carefully before attempting to assemble, install, operate or maintain the product described. Protect yourself and others by observing all safety information. The Safety Instructions are contained in the General Operating Instructions. Failure to comply with the safety instructions accompanying this product could result in personal injury and/or property damage! Retain instructions for future reference. AMT reserves the right to discontinue any model or change specifications at any time without incurring any obligation.

©2022 AMT Pump Company, A Subsidiary of The Gorman-Rupp Company, All Rights Reserved.

Periodic maintenance and inspection is required on all pumps to ensure proper operation. Unit must be clear of debris and sediment. Inspect for leaks and loose bolts. Failure to do so voids warranty.

# 2 Inch Dewatering Pumps

Refer to pump manual 1808-633-00 for General Operating and Safety Instructions.



## DESCRIPTION

These dewatering pumps are engine driven, self-priming (to 20 ft. lift), portable units. Clog resistant impeller is capable of handling solids up to 3/8" diameter. For use with non-flammable, non-abrasive liquids compatible with pump component materials.

## MAINTENANCE

### ⚠ WARNING

To prevent accidental starting, always remove spark plug or disconnect and ground spark plug wire before attempting to service or remove any component.

### MECHANICAL SEAL REPLACEMENT

Refer to figures 1A, 1B and 2.

**IMPORTANT:** Always replace seal assembly (Ref. no. 14) and shaft sleeve (Ref. no. 13) to ensure proper mating of mechanical seal components.

1. Unthread fasteners and remove casing from adapter.

**NOTE:** Inspect gasket. Replace if torn or damaged.

2. Unscrew impeller from engine shaft and remove impeller shims. Keep shims for assembly.

**NOTE:** To keep shaft from turning, remove shroud from engine and hold flywheel in place. Engine has a threaded shaft. To remove impeller, turn impeller CCW (facing engine shaft).

3. Slide shaft sleeve and seal head (the part with spring) from engine shaft.

4. Unthread fasteners and remove adapter from engine mounting face.

5. Push seal seat from adapter recess with a screwdriver.

6. Clean adapter recess before inserting a new seal seat.

**NOTE:** The precision lapped faces on mechanical seal are easily damaged. Handle your replacement seal carefully.

7. Carefully wipe polished surface of new seal seat with a clean cloth.

8. Wet rubber portion of seal seat with a light coating of soapy water. Press new seal seat squarely into cavity in adapter. If seal seat does not press squarely into cavity, it can be adjusted in place by pushing on it with a piece of cardboard between pipe and seal seat. Avoid scratching seal seat. (This is a lapped surface and must be handled very carefully).

9. Press new seal seat squarely into cavity in adapter. If seal seat does not press squarely into cavity, it can be adjusted in place by pushing on it with a piece of cardboard between pipe and seal seat. Avoid scratching seal seat. (This is a lapped surface and must be handled very carefully).

**NOTE:** Do not install a scratched, cracked or damaged seal seat; it will leak.

10. After seal seat is in place, ensure that it is clean and has not been marred.

11. Using a clean cloth, wipe shaft and make certain that it is perfectly clean.

12. Secure adapter on engine mounting face.

### ⚠ CAUTION

Tighten fasteners **EVENLY** to avoid cocking adapter on rabbet on engine mounting face.

13. Apply a light coating of soapy water to inside rubber portion of seal head and slide onto shaft sleeve. Slip shaft sleeve with seal cartridge onto engine shaft.

### ⚠ CAUTION

Do not touch or wipe polished part of seal cartridge.

14. Replace impeller shims.

**NOTE:** See shim adjustment below

15. Screw impeller back in place, tightening until it is against shaft shoulder.

16. Remount pump casing on adapter.

4222-250-00

## SHIM ADJUSTMENT

When installing a replacement impeller, it may be necessary to vary number of shims that will be required. This is done by adding 0.010" shim more than was removed and reassembling pump as follows:

**IMPORTANT:** When clearance between impeller and casing exceeds 1/16" at face of impeller or 1/8" on outside diameter of impeller, it may be necessary to take corrective action.

1. Ensure that casing is snugly in place and check shaft to make sure it is turning freely. If it turns freely, check to ensure that adapter and casing are seated firmly, compressing gasket where they meet. If they are not seated, tighten fasteners and recheck shaft for free turning. Tighten carefully, turning shaft while tightening. If shaft seizes before fasteners are completely tight, disassembly pump, remove one shim and repeat reassembly.
2. If at any time during shim adjustment shaft does not turn free, or a metal-to-metal rubbing can be heard or felt when turning shaft, repeat SHIM ADJUSTMENT procedure.

**NOTE:** Impeller must be as close as possible to casing in order to perform properly and retain suction capabilities.

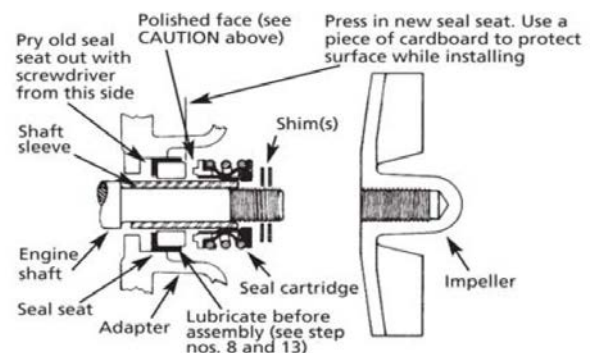

Figure 1A - Mechanical Seal Replacement

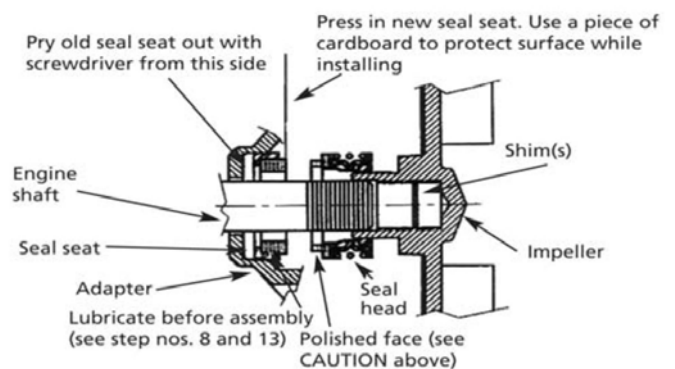

Figure 1B - Mechanical Seal Replacement

# 2 Inch Dewatering Pumps

**For Repair Parts contact dealer where pump was purchased.**

Please provide following information:

-Model Number

-Serial Number (if any)

Part description and number as shown in parts list

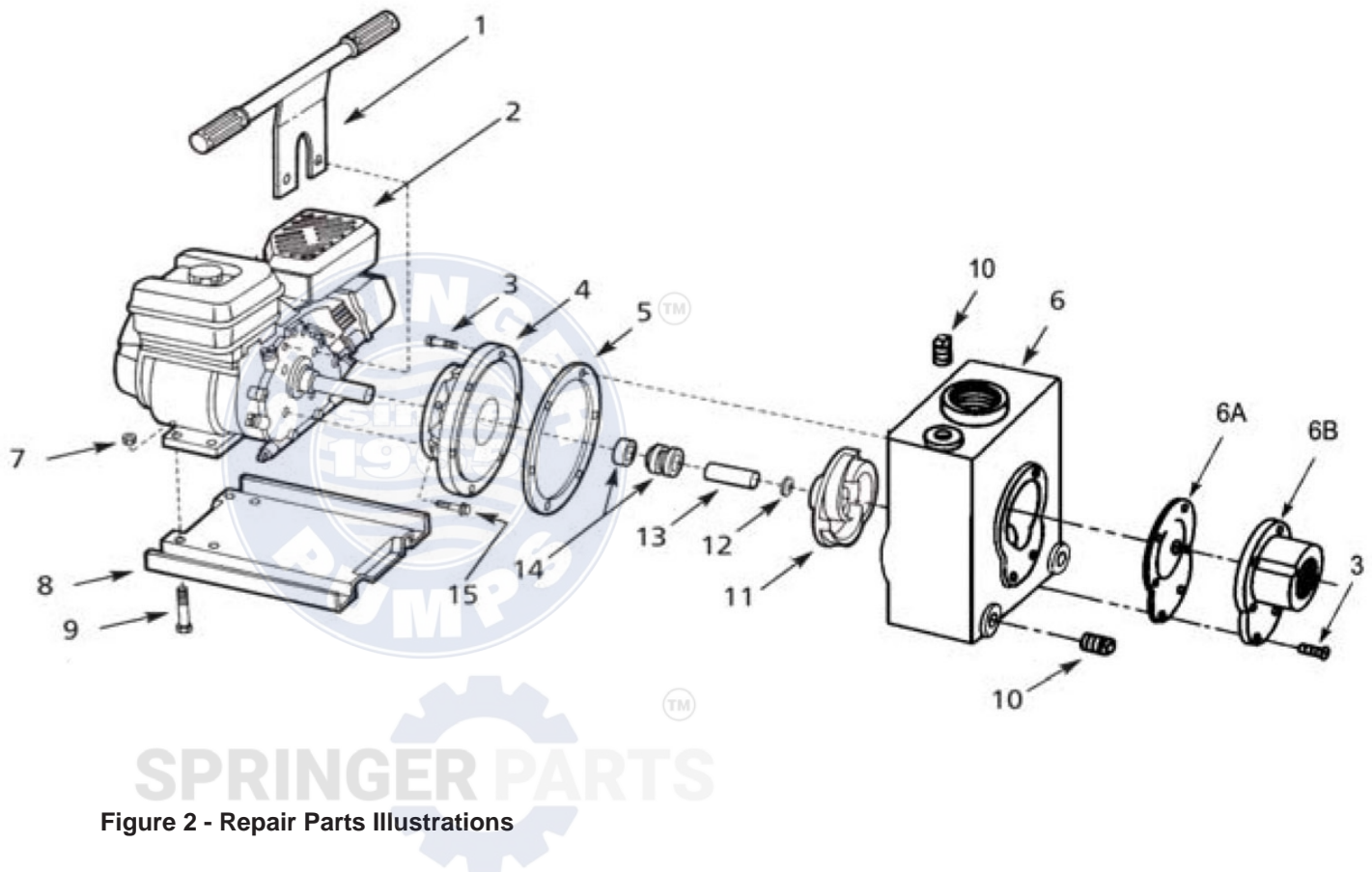

Figure 2 - Repair Parts Illustrations

## Repair Parts List

Ref No.	Description	Part Number for Models					Qty
		3/4" T-Shaft 4225-95 & 4225-V5	5/8" T-Shaft 4222-95 & 4222-V5	5/8" T-Shaft 4223-V5	5/8" T-Shaft 4226-95 4226-V5	5/8" T-Shaft 4227-95	
1	Carrying handle	1549-007-90	1549-007-90	1549-007-90	1549-007-90	1549-007-90	1
2	Engine	Discontinued	Discontinued	Discontinued	1639-036-00	1632-065-00	1
3	Fastener	*	*	*	*	*	6
4	Adapter	1474-000-02	1474-000-01	1474-000-01	1474-000-01	1474-000-01	1
5	Gasket	See Ref. No. 14	See Ref. No. 14	See Ref. No. 14	See Ref. No. 14	See Ref. No. 14	1
6	Casing (includes 3, 6A, 6B and 10)	4220-001-V5	4220-001-V5	4220-001-V5	4220-001-V5	4220-001-V5	1
6A	Flapper valve, Buna	1683-000-90	1683-000-90	1683-000-90	1683-000-90	1683-000-90	1
6A	Flapper valve, Viton	1683-000-91	1683-000-91	1683-000-91	1683-000-91	1683-000-91	1
6B	Suction Plate	1487-000-01	1487-000-01	1487-000-01	1487-000-01	1487-000-01	1
7	Fastener	*	*	*	*	*	4
8	Base	4220-100-00	4220-100-00	4220-100-00	4220-100-00	4220-100-00	1
9	Fastener	*	*	*	*	*	4
10	Pipe plug	*	*	*	*	*	3
11	Impeller	1493-012-02	1493-000-01	1496-002-01	1496-002-01	1496-002-01	1
12	Impeller shim set (Pkg)	3827-172-90	1658-000-90	1658-000-90	1658-000-90	1658-000-90	1
13	Shaft sleeve	Not Required	1483-149-00	1483-149-00	1483-149-00	1483-149-00	1
14	Seal kit - Buna N**	1006-999-BS	1007-999-B0	1007-999-B0	1007-999-B0	1007-999-B0	1
	Seal kit - Viton®**	1006-999-V0	1007-999-V0	1007-999-V0	1007-999-V0	1007-999-V0	1
15	Fastener	*	*	*	*	*	4

(\*) Standard hardware item, available locally.

(\*\*) Includes Ref. 5, 6A, 12, 13 and 14

NOTE: Pipe nipples are included with pump (not shown), Part No. 1696-044-00.

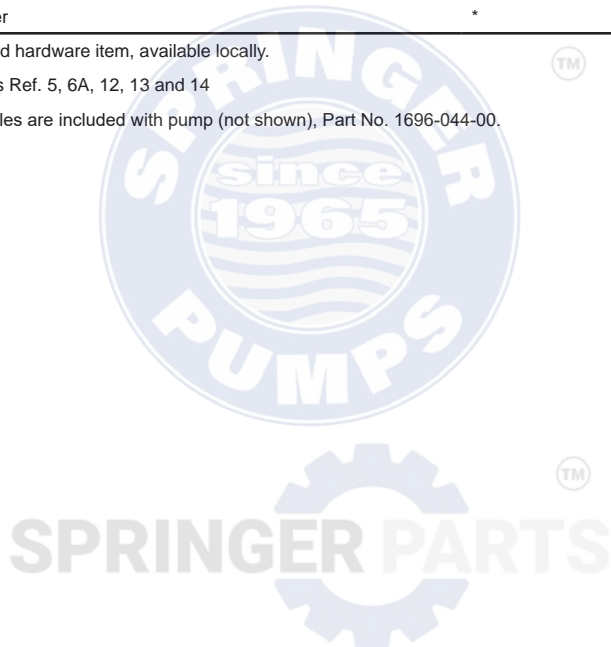



AMT Pump Company  
(herein "AMT")  
400 Spring Street  
Royersford, PA 19468  
Phone: (610) 948-3800  
Fax: (610) 948-5300  
www.amtpump.com

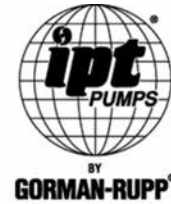

## General Information

**SALES POLICY:** AMT products are sold through our established Distributors. We do not sell direct to the consumer or organization not entitled to trade recognition. Therefore, possession of our catalogs and/or price list(s) does not infer an offer to sell.

**MINIMUM ORDER:** We appreciate your order, however, all orders are subject to a minimum \$35.00 net invoice charge (excluding freight). This applies to all pump and parts purchase orders.

**PRICES:** Prices are subject to change without notice. All orders accepted are subject to prices in effect at time of shipment.

**PAYMENT TERMS:** Terms, upon establishment of credit, are Net 30 days. Past due accounts may be subject to a service charge of 1.5% per month. Domestic or assignable letter of credit is required for all export trade.

**PAST DUE ACCOUNTS:** AMT reserves the right to withhold open account shipments on any past due account. Invoices are considered past due after thirty (30) days. In the interest of sound business, all orders are subject to approval of the Credit Department.

**SHIPPING INSTRUCTIONS:** All shipments will be made F.O.B. the factory. Where instructions for shipment do not appear on the order, the shipment will be made according to our best judgment. Full risk of loss (including transportation delays and losses) shall pass to the customer upon delivery of the products to the carrier at the F.O.B. point. When loss or delay occurs, primary responsibility for tracing rests with the customer. When there is LOSS or APPARENT VISIBLE DAMAGE to a shipment, when tendered for delivery, *DO NOT* give the carrier a clear receipt. Note such damage on the carrier's delivery receipt and *HAVE THE DRIVER SIGN THE RECEIPT*.

**PRODUCT REVISIONS:** AMT reserves the right to discontinue, change or improve its products or any portions thereof without being obligated to provide such a change or improvement for units sold and/or shipped prior to such a change or improvement.

**LEAD TIME:** Products designated "Quick Ship Product", also referred to as "QSP" will normally be shipped within 24 hours of receipt of a non-cancellable purchase order. Only limited quantities of "QSP" pumps are available.

**STANDARD LEAD TIME:** Lead time is two weeks for all non "QSP" product. AMT reserves the right to revise lead times as required due to availability of materials and all other causes beyond our control.

**VIP SHIPMENT:** Select AMT and IPT branded pumps are available for next day shipment for non-QSP (Quick Ship Products) items and subjected to a specific model surcharge per unit noted in the respective price book. Requires calling for availability, confirmation and a non-cancellable purchase order or credit card payment prior to shipment. The expedited shipping charges are an additional cost added separately from the VIP charges per item. AMT reserves the right to revise lead times as required due to availability of materials and all other causes beyond our control. QSP quantities are limited as determined by AMT.

ALL purchase orders must be submitted via hard copy sent to AMT customer service department by fax, EDI or e-mail.

**RETURN GOODS POLICY:** Goods shall not be returned without a return goods authorization number (RGA) issued by AMT customer service. The RGA number must be listed on the packing list. Only current model and part numbers with a valid date code may be returned (within one year from date of purchase). **A 20% restocking and packaging charge will apply to all returns. All shipping charges must be pre-paid. No exceptions.**

**ORDER CHANGES BY CUSTOMER:** Orders in process may not be changed except with written consent and may be subject to special charges.

## 12 Month Limited Warranty

### EXTENT AND DURATION OF LIMITED WARRANTY

**Coverage:** AMT Pump Company (herein "AMT") or IPT Pumps by Gorman-Rupp (herein "IPT") or Gorman-Rupp Industries Division of the The Gorman-Rupp Company, Patterson, or the Gorman-Rupp Company (herein referred to as "G-R Unit") each individually warrants that its products and parts shall be free from defects in material and workmanship for twelve (12) months from the date of purchase by the original end user when installation is made and maintenance is performed in accordance with G-R Unit's recommendations. Wear and tear resulting from use and items normally consumed in use are not covered.

### EXCEPTIONS

( A ) This Limited Warranty shall not apply to mechanical seals in AMT or IPT pumps and the following products and parts: engines, motors, trade accessories and all other products, components, parts and materials not manufactured by the G-R Units. These items may, however, be covered by the warranties of their respective manufacturers. ( B ) This warranty does not extend to or apply to any unit which has been repaired or altered at any place other than by a G-R Unit, or by persons not expressly approved by a G-R Unit to make repairs or alterations, nor to any unit the serial number, model number or identification of which has been removed, defaced or altered. ( C ) This warranty does not extend to any product manufactured by a G-R Unit, which has been subjected to mis-use, neglect, accident, improper installation, or use in violation of instructions furnished by a G-R Unit. ( D ) Pump Kits: This warranty does not extend to any product sold by a G-R Unit unassembled as a Pump Kit. Pump Kits are warranted against defects in material and workmanship for 60 days from the date of shipment from a G-R Unit. Any Pump Kit parts deemed defective by a G-R Unit will be replaced free of charge within 60 days of shipment. Pump Kits are not returnable for credit.

### LIMITATIONS

**THE G-R UNITS' SOLE AND EXCLUSIVE WARRANTY WITH RESPECT TO THEIR PRODUCTS AND PARTS IS THIS LIMITED WARRANTY. THIS LIMITED WARRANTY IS IN LIEU OF ALL OTHER EXPRESS AND/OR IMPLIED WARRANTIES, INCLUDING IMPLIED WARRANTIES OF MERCHANTABILITY AND FITNESS FOR PARTICULAR PURPOSE.**

### EXCLUSIVE REMEDY AND DAMAGES

The sole and exclusive remedy for breach of this Warranty by a G-R Unit and the entire extent of its liability for such breach or for damages arising from the use of the products and parts covered under this Limited Warranty, shall be as follows:

- Repair or Replacement:** If inspection shows that any G-R Unit product or part covered under this Limited Warranty is defective in materials or workmanship, the G-R Unit shall repair or replace the defective or non-conforming product or part without charge, whichever the G-R Unit chooses. You must have properly maintained and used the product or part claimed to be defective in accordance with the maintenance schedule or manual, which comes with the product. No allowance will be made for labor, installation, removal, transportation or other charges incurred by you in connection with such repair or replacement.
- To obtain the above remedy:
  - Immediately notify the G-R Unit upon discovery of the claimed defect in materials or workmanship and provide the serial number or date code of the product and/or part(s) or provide the G-R Unit with the invoice or bill of sale referencing the product by no later than the expiration date of the warranty period.
  - The G-R Unit will advise whether inspection will be necessary and how whether repair or replacement will be made. If inspection by the G-R Unit is necessary, the pump or defective part must be sent freight pre-paid to the G-R Unit. Return shipment will be F.O.B. the G-R Unit's plant.
  - Return Goods Authorization Requirement:** No product will be accepted for return or replacement without the prior written authorization of the G-R Unit. Upon such authorization, and in accordance with instructions from the G-R Unit, the product will be returned to the G-R Unit, shipping charges prepaid by the Buyer.
- Damages:** The G-R Unit's liability for damages for breach of this Limited Warranty shall not exceed the amount of the purchase price of the product or part(s) in respect to which Such damages are claimed. **IN NO EVENT SHALL THE G-R UNITS BE LIABLE FOR INCIDENTAL, CONSEQUENTIAL OR SPECIAL DAMAGES FOR BREACH OF THIS LIMITED WARRANTY.**

Some states do not allow the exclusion or limitation of incidental or consequential damages, so the above limitation or exclusion may not apply to you. This Limited Warranty gives you specific legal rights, and you may also have other rights, which vary from state to state.

AMT Pump Company, A Gorman-Rupp Company, 400 Spring Street, Royersford, PA 19468 USA