

SUBMERSIBLE DEWATERING PUMP

Series: 2AHS
0.5, 1 & 2 HP / 3450 RPM
Discharge: 2"
Solids handling: 1/4"



DISCHARGE

2" NPT vertical, adapter included.

LIQUID TEMPERATURE

104°F (40°C)

PUMP BODY

Cast iron FC-200

MOTOR HOUSING

Aluminum alloy ADC12

OIL CHAMBER

Cast iron FC-200

IMPELLER

Design: 8 vane, semi-open *Vortex*.

Material: Hytrel® thermoplastic elastomer

SHAFT

410 series stainless steel

HARDWARE

304 series stainless steel

O-RINGS

Nitrile rubber (NBR)

PAINT

Air dry enamel, water based.

SEAL

Design: double, mechanical, oil filled chamber.

Material: upper part of carbon-ceramic, lower part of silicone carbide. Stainless steel hardware.

CORD ENTRY

15 ft of neoprene cord, sealed against moisture.

BEARINGS

Ball, single row, permanently oil lubricated for 60,000 hours of work. Designed for radial and axial loads.

MOTOR

Dry type submersible motor, 1 & 3 phase, 115 & 230 volts, 60 Hz, 3450 RPM. For continuous duty, with thermal protector IP68 in winding, insulation class B.

STRAINER

Polyvinyl chloride (PVC)

HANDLE

Nylon 6

PUMP OPERATION

Available as "A" Automatic model or Manual operation (no level control). A control panel is needed for the 3 phase pumps to operate in automatic.

Last update: JUL/11/2023

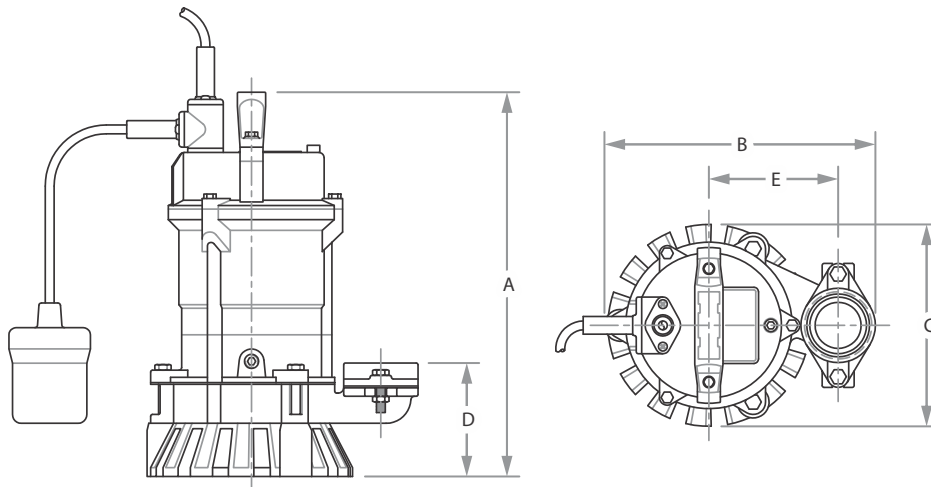

MODEL	PART No.	HP	VOLTS	PHASE	RPM (Nominal)	MAX AMPS	CORD SIZE	A	B	C	D	E	WEIGHT (pounds)
2AHS051	62180101	0.5	115	1	3450	6.6	16AWG/3C	13.86"	9.57"	Ø7"	4.25"	4.61"	26
2AHS051A	62180102												
2AHS101	62180103	1	115	1	3450	12	16 AWG/3C	14.84"	10.98"	Ø7"	4.75"	5.24"	33
2AHS101A	62180104												
2AHS103	62180105	1	230	3	3450	4	16 AWG/4C	14.84"	10.98"	Ø7"	4.75"	5.24"	33
2AHS203	62180107												

A = Automatic Float Switch. A control panel is needed for the 3 phase pumps to operate in automatic.

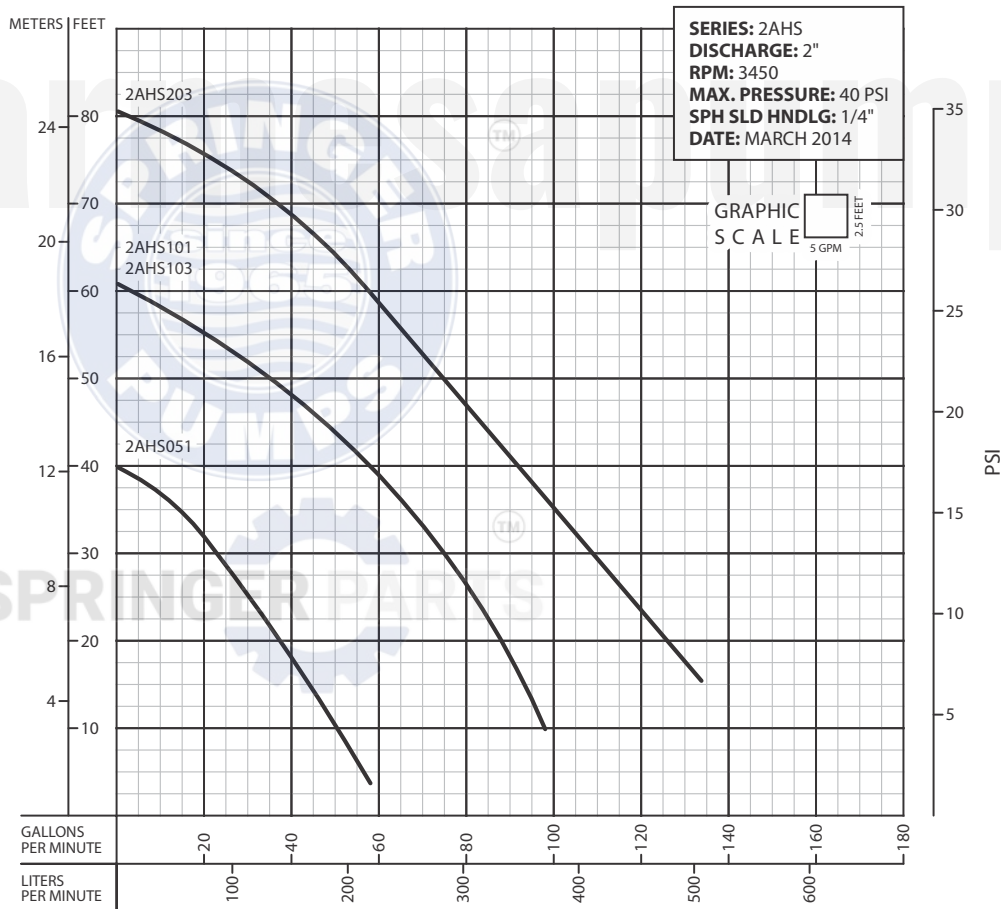

IMPORTANT!

1. Never use this pump to handle explosive liquids.
2. This pump is not approved to be used in swimming pools, recreational installations or any application where human contact may be common.
3. Pump may be operated "dry" for extended periods without damage to motor and/or seals.
4. Testing is performed with water specific gravity of 1.0 @ 68 °F (20 °C); other fluids may vary performance.