



SUBMERSIBLE SOLIDS HANDLING PUMP

Series: 3BSE-SS
1.5 & 2 HP / 1750 RPM
Discharge: 3"
Spherical solids handling: 2½"



DISCHARGE

3" NPT female, vertical, bolt on flange.

LIQUID TEMPERATURE

104°F (40°C)

VOLUTE

Cast iron ASTM A-48 class 30

MOTOR HOUSING

Cast iron ASTM A-48 class 30

SEAL PLATE

Cast iron ASTM A-48 class 30

IMPELLER

Design: 2 vane, open, with vanes on back side.

Material: cast iron ASTM A-48 class 30

SHAFT

416 series stainless steel

HARDWARE

300 series stainless steel

SQUARE RINGS

Buna-N

PAINT

Air dry enamel, water based.

SEAL

Design: inboard, single mechanical, oil filled chamber.

Material: silicon carbide, Buna-N elastomer and stainless steel hardware.

CORD ENTRY

25 ft of neoprene cord SJO 14/3, sealed against moisture.

BEARINGS

Upper: ball, single row, oil lubricated, for radial load.

Lower: ball, single row, oil lubricated, for radial and thrust load.

MOTOR

Single phase: NEMA L, permanent split capacitor, 200/230 volts, 60 Hz, 1750 RPM, oil filled, with overload protection in motor.

Three phase: NEMA B, 200/230 & 460 volts, 60 Hz, 1750 RPM, oil filled. Requires overload protection to be included in control panel.

OPTIONAL EQUIPMENT

Additional cord

Last update: JUL/11/2023

North America: 866 777 6060
Int'l: +1 267 404 2910

Springer Pumps
Springer Parts

www.springerpumps.com
www.springerparts.com

TECHNICAL DATA SHEET

SPECIFICATIONS

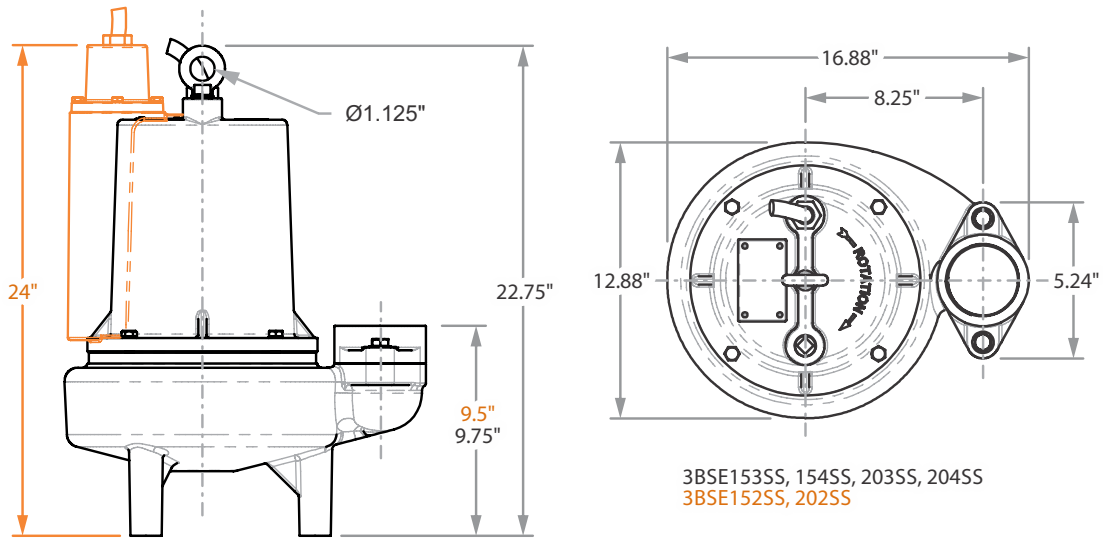

MODEL	PART No.	HP	VOLTS	PHASE	MAX. AMPS.	LOCKED ROTOR AMPS.	NEMA CODE	CORD SIZE	CORD TYPE	CORD LENGTH	WEIGHT (pounds)
3BSE152SS	62170010	1.5	200/230	1	12.6	23	B	10/3	SJO	25'	225
3BSE153SS	62170011		200/230	3	11.6	36	H/L	10/4		25'	207
3BSE154SS	62170012		460	3	5.8	17.5	L	10/4		25'	207
3BSE202SS	62170013	2	200/230	1	14.5	29	B	10/3	SJO	25'	229
3BSE203SS	62170014		200/230	3	14	50.8	J/M	10/4		25'	207
3BSE204SS	62170015		460	3	7	25.4	M	10/4		25'	207

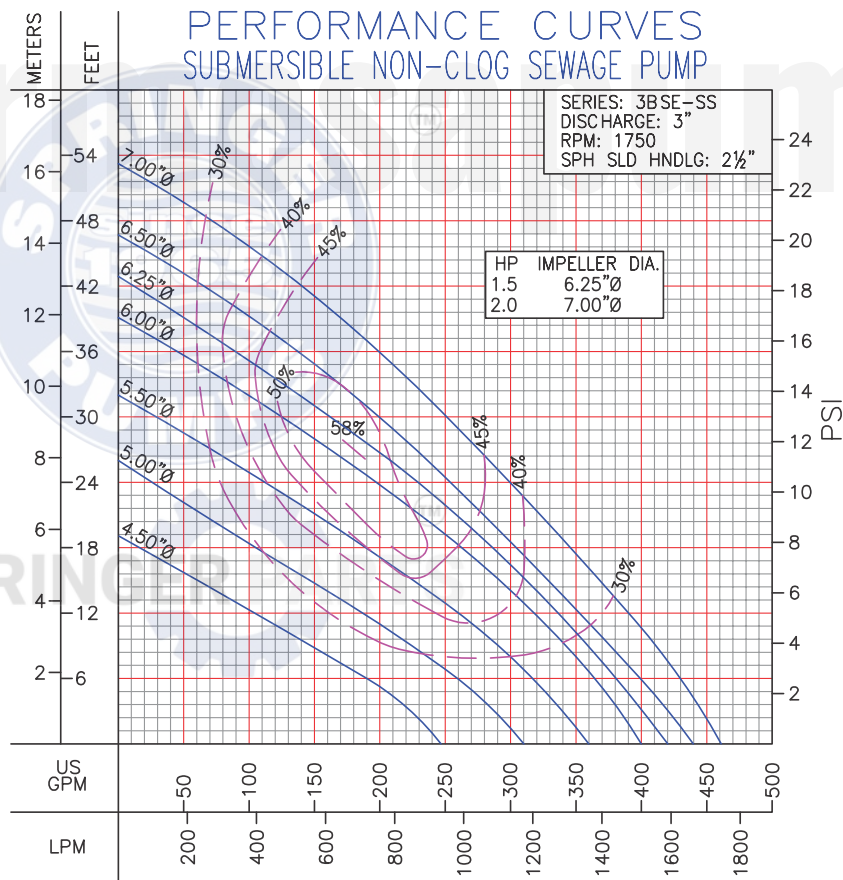

IMPORTANT!

1. Never use this pump to handle explosive liquids.
2. This pump is not approved to be used in swimming pools, recreational installations or any application where human contact may be common.
3. Pump may be operated "dry" for extended periods without damage to motor and/or seals.
4. Testing is performed with water specific gravity of 1.0 @ 68 °F (20 °C); other fluids may vary performance.

barmesapumps.com/US

North America: 866 777 6060
Int'l: +1 267 404 2910

Springer Pumps
Springer Parts

www.springerpumps.com
www.springerparts.com