



SUBMERSIBLE SOLIDS HANDLING PUMP

Series: 3BSE-SS
1 HP / 1750 RPM
Discharge: 3" (2" optional)
Spherical solids handling: 2"



DISCHARGE

3" NPT female, vertical, bolt on flange. 2" discharge flange also available.

LIQUID TEMPERATURE

104°F (40°C) continuous

VOLUTE

Cast iron ASTM A-48 class 30

MOTOR HOUSING

Cast iron ASTM A-48 class 30

SEAL PLATE

Cast iron ASTM A-48 class 30

IMPELLER

Design: 2 vane, open, with vanes on back side.

Material: cast iron ASTM A-48 class 30

SHAFT

416 series stainless steel

HARDWARE

300 series stainless steel

SQUARE RINGS

Buna-N

PAINT

Air dry enamel, water based.

SEAL

Design: inboard, single mechanical, oil filled chamber.

Material: silicon carbide, Buna-N elastomer and stainless steel hardware.

CORD ENTRY

30 ft of neoprene cord SJO 14/3, sealed against moisture.

BEARINGS

Upper: ball, single row, oil lubricated, for radial load.

Lower: ball, single row, oil lubricated, for radial and thrust load.

MOTOR

Single phase: NEMA L, permanent split capacitor, 230 volts, 60 Hz, 1750 RPM, oil filled, overload protection in motor.

Three phase: NEMA B, 200/230 & 460 volts, 60 Hz, 1750 RPM, oil filled. Requires overload protection to be included in control panel.

OPTIONAL EQUIPMENT

Additional cord, tungsten carbide seal.

Last update: JUL/11/2023

North America: 866 777 6060
Int'l: +1 267 404 2910

Springer Pumps
Springer Parts

www.springerpumps.com
www.springerparts.com

TECHNICAL DATA SHEET

SPECIFICATIONS

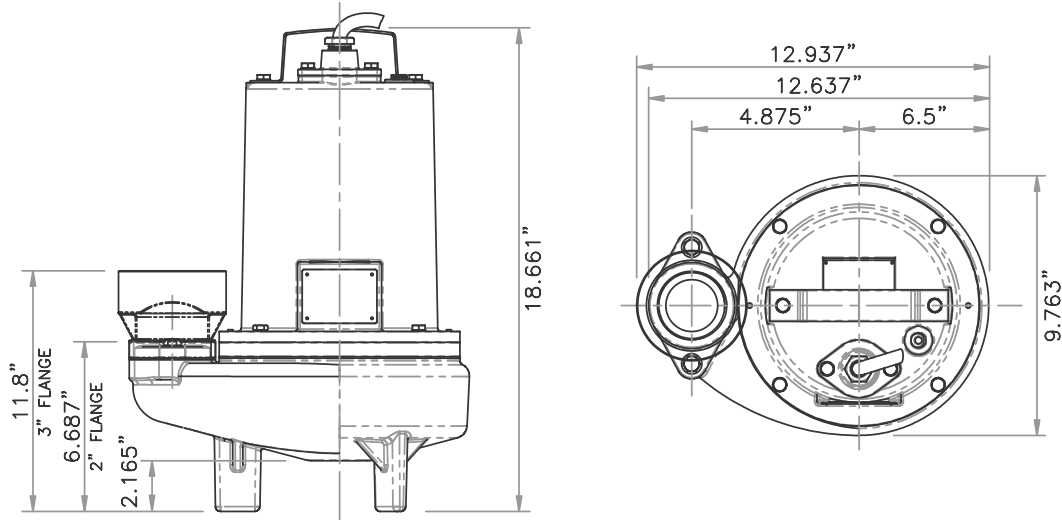

MODEL	PART No.	HP	VOLTS	PHASE	RPM (Nominal)	MAX AMPS	LOCKED ROTOR AMPS	NEMA CODE	CORD SIZE	CORD TYPE	CORD O.D.	WEIGHT (pounds)
3BSE102SS	62180508	1	230	1	1750	8.3	17.5	A	14/3	SJO	0.69"	84
3BSE103SS	62180509	1	200/230	3	1750	6	16	B	14/4	SO	0.75"	82
3BSE104SS	62180510	1	460	3	1750	3	8	B	14/4	SO	0.75"	82

- 2" discharge flange is available for these models, (this change the model to 2BSE-SS).

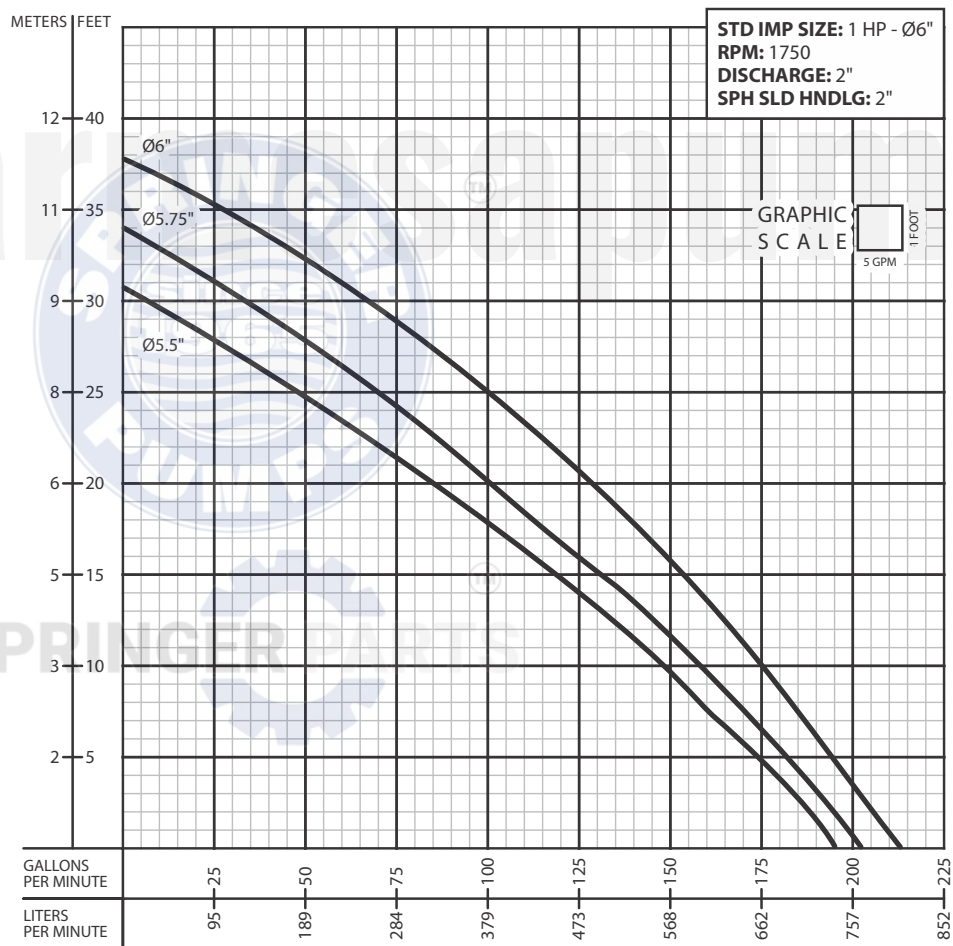

IMPORTANT!

1. Never use this pump to handle explosive liquids.
2. This pump is not approved to be used in swimming pools, recreational installations or any application where human contact may be common.
3. Pump may be operated "dry" for extended periods without damage to motor and/or seals.
4. Testing is performed with water specific gravity of 1.0 @ 68 °F (20 °C); other fluids may vary performance.

North America: 866 777 6060
 Int'l: +1 267 404 2910

Springer Pumps
 Springer Parts

barmesapumps.com/US
www.springerpumps.com
www.springerparts.com