



SUBMERSIBLE SOLIDS HANDLING PUMP

Series: **4SWH-DS**

20 - 100 HP @ 1750 RPM

10 - 40 HP @ 1150 RPM

Discharge: 4"

Spherical solids handling: 3"



DISCHARGE

4", 125 lb, horizontal flange, slotted to accommodate 100 mm ISO flange.

LIQUID TEMPERATURE

104°F (40°C) continuous

VOLUTE

Cast iron ASTM A-48 class 30

MOTOR HOUSING

Cast iron ASTM A-48 class 30

SEAL PLATE

Cast iron ASTM A-48 class 30

IMPELLER

Design: enclosed dual vane with pump-out vanes on back side. Dynamically balanced.

Material: ductile iron ASTM A-536, 65-45-12.

SHAFT

416 series stainless steel

HARDWARE

300 series stainless steel

O-RINGS

Buna-N

LIFTING BAIL

300 series stainless steel

MAX. SUBMERGENCE

66 ft (20 m)

PAINT

Epoxy

SEAL

Design: tandem, mechanical, in oil filled reservoir.

Material: inboard rotating faces, carbon; stationary faces, ceramic. Outboard rotating and stationary faces, silicon carbide. Buna-N elastomer and 300 series stainless steel hardware.

CORDENTRY

40 ft cord, epoxy sealed housing, with secondary pressure grommet for sealing and strain relief.

BEARINGS

Upper: ball, single row and oil lubricated, for radial load.

Lower: ball, double row and oil lubricated, for radial and thrust loads.

MOTOR

NEMA three phase 208/230 & 460 V, premium efficiency, oil-filled, squirrel cage induction, inverted duty rated. Class H insulation. Requires overload protection in control panel.

MOISTURE SENSOR

Normally open (N/O), requires relay and panel.

TEMPERATURE SENSOR

Normally closed (N/C), to be wired in series with control circuit.

OPTIONAL EQUIPMENT

Slide rail coupling, leg kit and seal material.

Last update: mar/13/2024

North America: 866 777 6060
Int'l: +1 267 404 2910

Springer Pumps
Springer Parts

www.springerpumps.com
www.springerparts.com

TECHNICAL DATA SHEET

SPECIFICATIONS

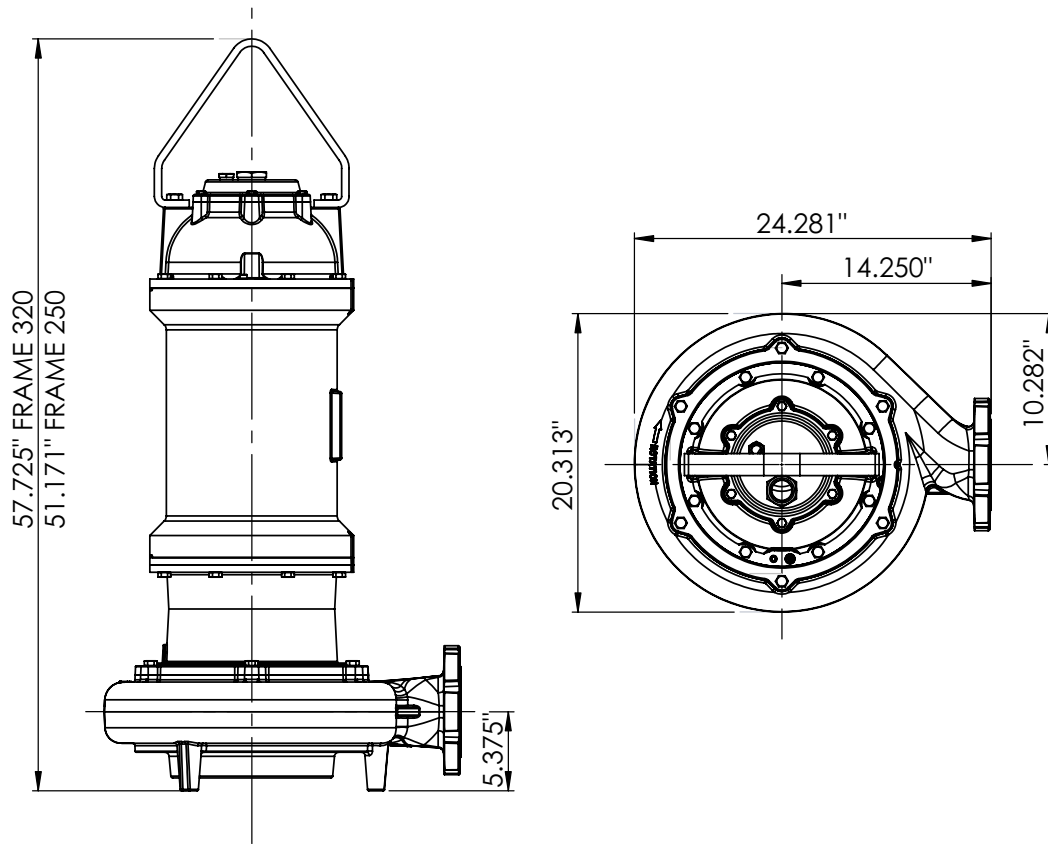

MODEL	PART No.	HP	PH	VOLTS	RPM (nom)	NEMA START CODE	FULL LOAD AMPS	SF	AMPS SF	FRAME	POWER CORD SIZE	WEIGHT (lb)
4SWH20034DS	62172029	20	3	208/230	1750	J	52.8/48	1.15	60.7/55	250	8/4	615
4SWH20044DS	62172030			460			24.1		27.3			
4SWH25034DS	62172031	25	3	208/230	1750	G	65/59	1.15	74.8/67.8	250	8/4	633
4SWH25044DS	62172032			460			29.5		34			
4SWH30034DS	62172033	30	3	208/230	1750	E	93.4/82.3	1.15	107/94	250	8/4	653
4SWH30044DS	62172034			F		46.7	53					
4SWH40044DS	62172035	40	3	460	1750	E	48	1.15	55.2	250	8/4	683
4SWH50044DS	62172036	50	3	460	1750	F	65	1.15	74.8	320	2/3	760
4SWH60044DS	62172037	60	3	460	1750	E	76.6	1.15	88.1	320	2/3	782
4SWH75044DS	62172038	75	3	460	1750	G	105	1.15	120.7	320	2/3	806
4SWH100044DS	62172039	100	3	460	1750	E	132.5	1.15	152.4	400	2/3	927
4SWH10036DS	62172042	10	3	208/230	1150	E	29/27	1.15	37/33	250	10/4	598
4SWH10046DS	62172043			460			13.5		18.4			
4SWH15036DS	62172044	15	3	208/230	1150	H	47.43	1.15	54/49.4	250	10/4	623
4SWH15046DS	62172045			460			21.5		24.7			
4SWH20036DS	62172046	20	3	208/230	1150	E	44.3/49.2	1.15	51/56.6	250	8/4	642
4SWH20046DS	62172047			460			24.6		28.3			
4SWH25036DS	62172048	25	3	208/230	1150	G	72.9/68.7	1.15	83.8/66.6	320	8/4	719
4SWH25046DS	62172049			460			36.4		41.8			
4SWH30036DS	62172050	30	3	208/230	1150	E	88/80	1.15	101/92	320	8/4	740
4SWH30046DS	62172051			460			44		50.6			
4SWH40046DS	62172052	40	3	460	1150	E	107	1.15	123	320	8/4	762

Note: Seal moisture and temperature sensor cord in all models size 18/5.

IMPORTANT!

1. Never use this pump to handle explosive liquids.
2. This pump is not approved to be used in swimming pools, recreational installations or any application where human contact may be common.
3. Moisture and temperature sensors must be connected to validate the warranty.
4. This pump is not appropriate for those applications specified as class 1 division 1 hazardous locations.

North America: 866 777 6060
Int'l: +1 267 404 2910

Springer Pumps
Springer Parts

barmesapumps.com/US
www.springerpumps.com
www.springerparts.com



PERFORMANCE CURVES

Submersible Solids

Handling Pump

Series: **4SWH-DS @ 1750 RPM**

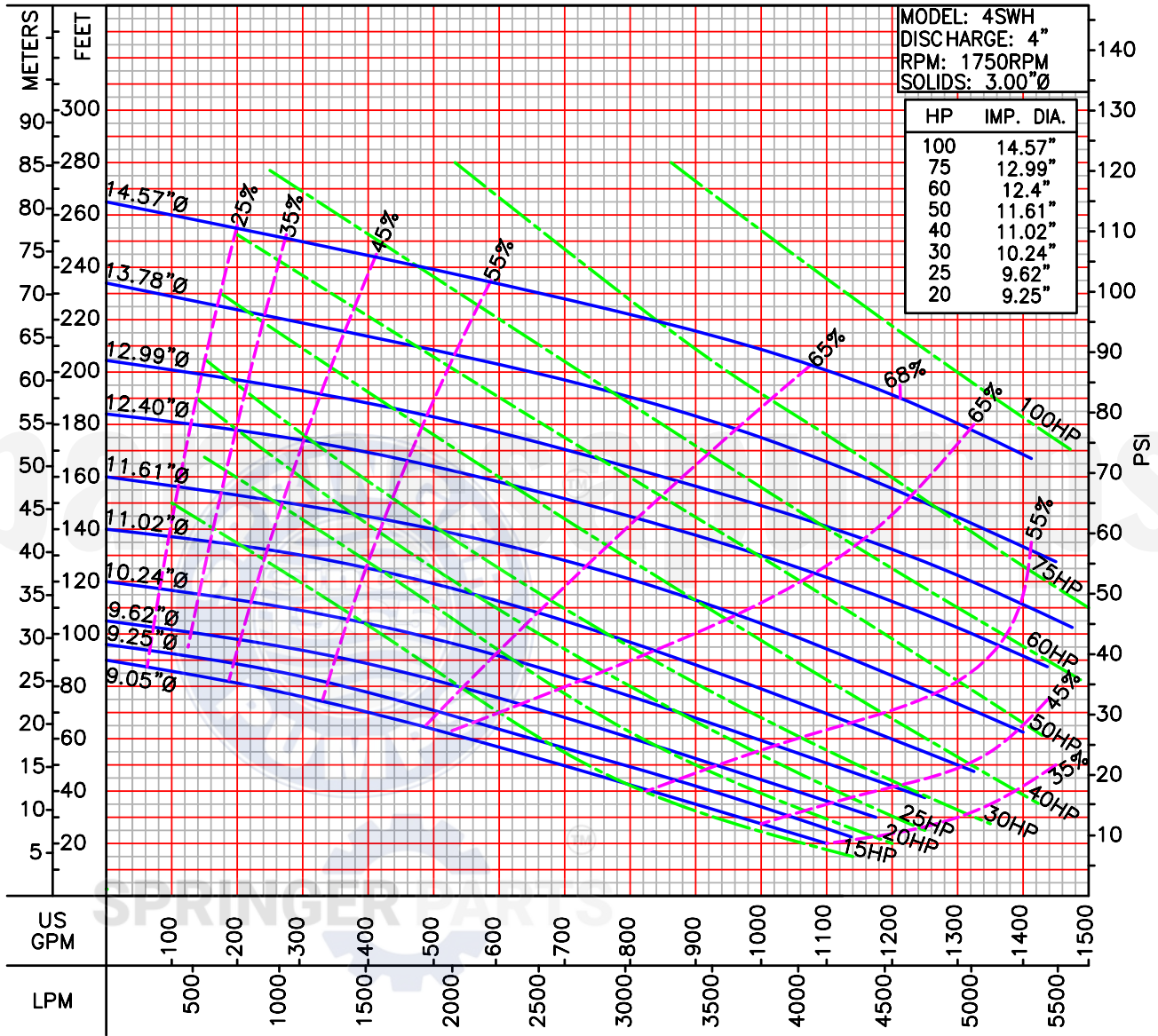

LIQUID: WATER
SPECIFIC GRAVITY: 1.00

TEMPERATURE: 70 °F (21 °C)
MAXIMUM DIA. SOLIDS: 3.00"Ø

PERFORMANCE CURVES

Submersible Solids

Handling Pump

Series: **4SWH-DS @ 1150 RPM**

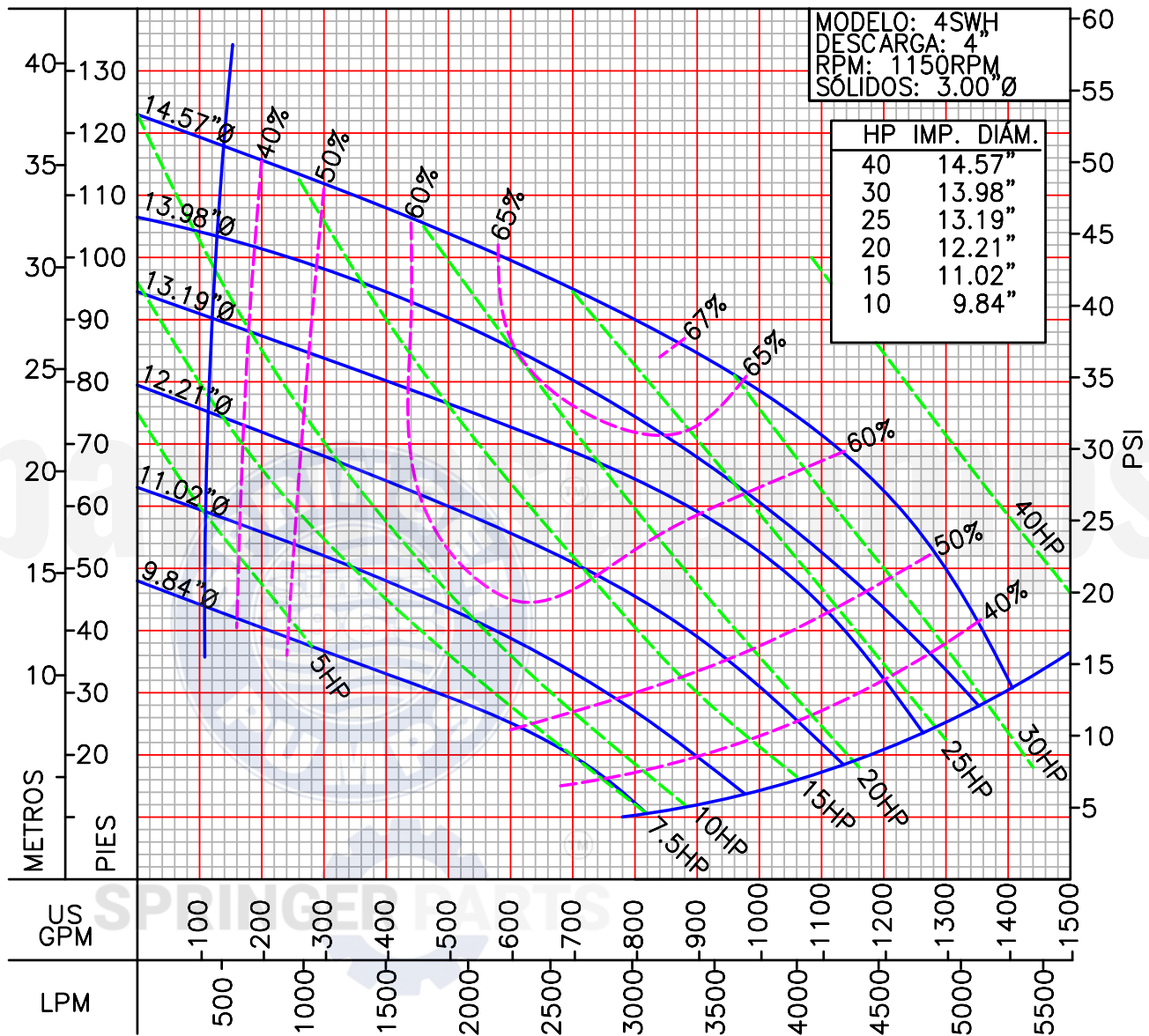

LÍQUIDO: AGUA
GRAVEDAD ESPECÍFICA: 1.00

TEMPERATURA: 21 °C (70 °F)
DIÁM. MÁXIMO SÓLIDOS: 3.00"Ø