



SUBMERSIBLE SOLIDS HANDLING PUMP

Series: **6SWH-DS**

25 - 125 HP @ 1750 RPM

7.5 - 40 HP @ 1150 RPM

Discharge: 6"

Spherical solids handling: 3"



DISCHARGE

6", 125 lb, horizontal flange, slotted to accommodate 150 mm ISO flange.

LIQUID TEMPERATURE

104°F (40°C) continuous

VOLUTE

Cast iron ASTM A-48 class 30

MOTOR HOUSING

Cast iron ASTM A-48 class 30

SEAL PLATE

Cast iron ASTM A-48 class 30

IMPELLER

Design: enclosed dual vane with pump-out vanes on back side. Dynamically balanced.

Material: ductile iron ASTM A-536, 65-45-12.

SHAFT

416 series stainless steel

HARDWARE

300 series stainless steel

O-RINGS

Buna-N

LIFTING BAIL

300 series stainless steel

MAX. SUBMERGENCE

66 ft (20 m)

PAINT

Epoxy

DOUBLE MECHANICAL SEAL

Design: tandem, mechanical, in oil filled reservoir.

Material: inboard rotating faces, carbon; stationary faces, ceramic. Outboard rotating and stationary faces, silicon carbide. Buna-N elastomer and 300 series stainless steel hardware.

CORD ENTRY

40 ft cord, epoxy sealed housing, with secondary pressure grommet for sealing and strain relief.

BEARINGS

Upper: ball, single row and oil lubricated, for radial load.

Lower: ball, double row and oil lubricated, for radial and thrust loads.

MOTOR

NEMA three phase 208/230 & 460 V, premium efficiency, oil-filled, squirrel cage induction, inverted duty rated. Class H insulation. Requires overload protection in control panel.

MOISTURE SENSOR

Normally open (N/O), requires relay and panel.

TEMPERATURE SENSOR

Normally closed (N/C), to be wired in series with control circuit.

OPTIONAL EQUIPMENT

Slide rail coupling, leg kit and seal material.

Last update: MAR/13/2024

North America: 866 777 6060
Int'l: +1 267 404 2910

Springer Pumps
Springer Parts

www.springerpumps.com
www.springerparts.com

TECHNICAL DATA SHEET

SPECIFICATIONS

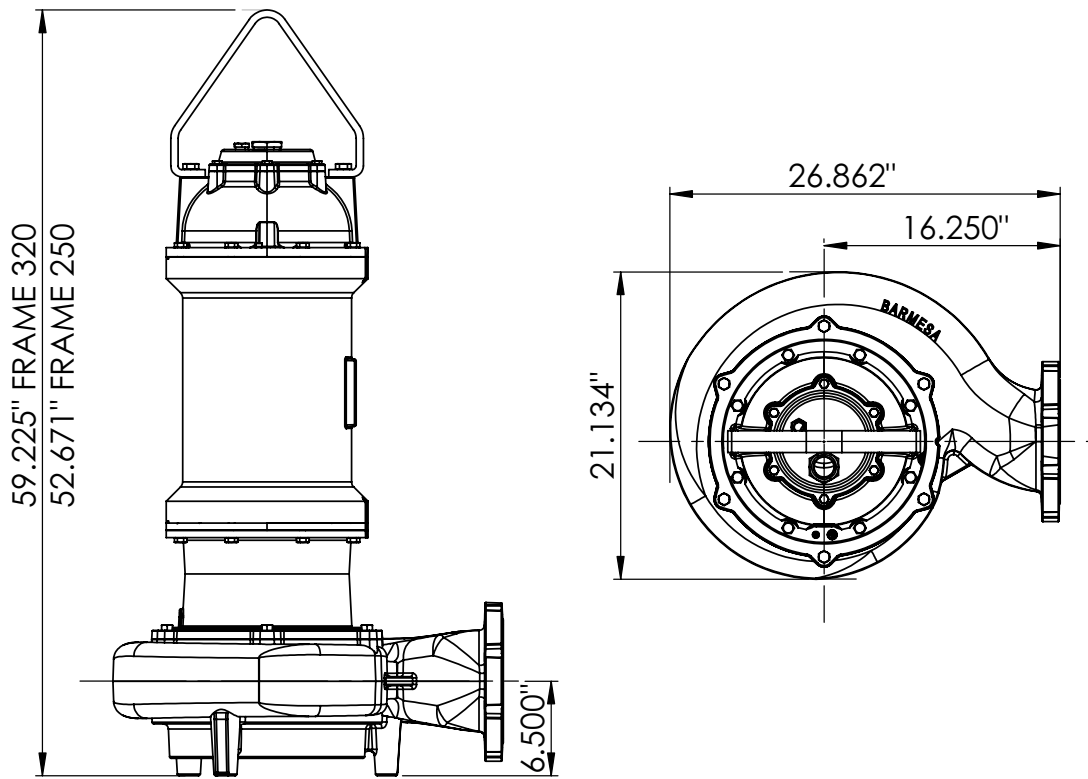

MODEL	PART No.	HP	PH	VOLTS	RPM (nom)	NEMA START CODE	FULL LOAD AMPS	SF	AMPS SF	FRAME	POWER CORD SIZE	WEIGHT (lb)
6SWH25034DS	62172123	25	3	208/230	1750	G	65/59	1.15	74.8/67.8	250	2/3	985
6SWH25044DS	62172124			460			29.5		34			
6SWH30034DS	62172125	30	3	208/230	1750	E	93.4/82.3	1.15	107/94	250	2/3	1016
6SWH30044DS	62172126			460			46.7		53			
6SWH40044DS	62172127	40	3	460	1750	E	48	1.15	55.2	250	2/3	1046
6SWH50044DS	62172128	50	3	460	1750	F	65	1.15	74.8	320	2/3	1123
6SWH60044DS	62172129	60	3	460	1750	E	76.6	1.15	88.1	320	2/3	1156
6SWH75044DS	62172130	75	3	460	1750	G	105	1.15	120.7	320	2/3	1191
6SWH100044DS	62172131	100	3	460	1750	E	132.5	1.15	152.4	400	2/3	1226
6SWH125044DS	62172132	125	3	460	1750	F	164.3	1.15	189	400	2/3	1263
6SWH7536DS	62172133	7.5	3	208/230	1150	J	22/20	1.15	23	250	10/4	798
6SWH7546DS	62172134			460			10		11.5			
6SWH10036DS	62172135	10	3	208/230	1150	E	29/27	1.15	37/33	250	10/4	815
6SWH10046DS	62172136			460			13.5		18.4			
6SWH15036DS	62172137	15	3	208/230	1150	H	47/43	1.15	54/49.4	250	2/3	840
6SWH15046DS	62172138			460			21.5		24.7			
6SWH20036DS	62172139	20	3	208/230	1150	E	44.3/49.2	1.15	51/56.6	250	2/3	865
6SWH20046DS	62172140			460			24.6		28.3			
6SWH25036DS	62172141	25	3	208/230	1150	G	72.9/68.7	1.15	83.8/66.6	320	2/3	955
6SWH25046DS	62172142			460			36.4		41.80			
6SWH30036DS	62172143	30	3	208/230	1150	E	88/80	1.15	101/92	320	2/3	983
6SWH30046DS	62172144			460			44		50.6			
6SWH40046DS	62172146	40	3	460	1150	E	107	1.15	123	320	2/3	1013

Note: Seal moisture and temperature sensor cord in all models size 18/5.

IMPORTANT!

1. Never use this pump to handle explosive liquids.
2. This pump is not approved to be used in swimming pools, recreational installations or any application where human contact may be common.
3. Moisture and temperature sensors must be connected to validate the warranty.
4. This pump is not appropriate for those applications specified as class 1 division 1 hazardous locations.

North America: 866 777 6060
Int'l: +1 267 404 2910

Springer Pumps
Springer Parts

barnesapumps.com/US
www.springerpumps.com
www.springerparts.com

PERFORMANCE CURVES

Submersible Solids

Handling Pumps

Series: **6SWH-DS @ 1750 RPM**

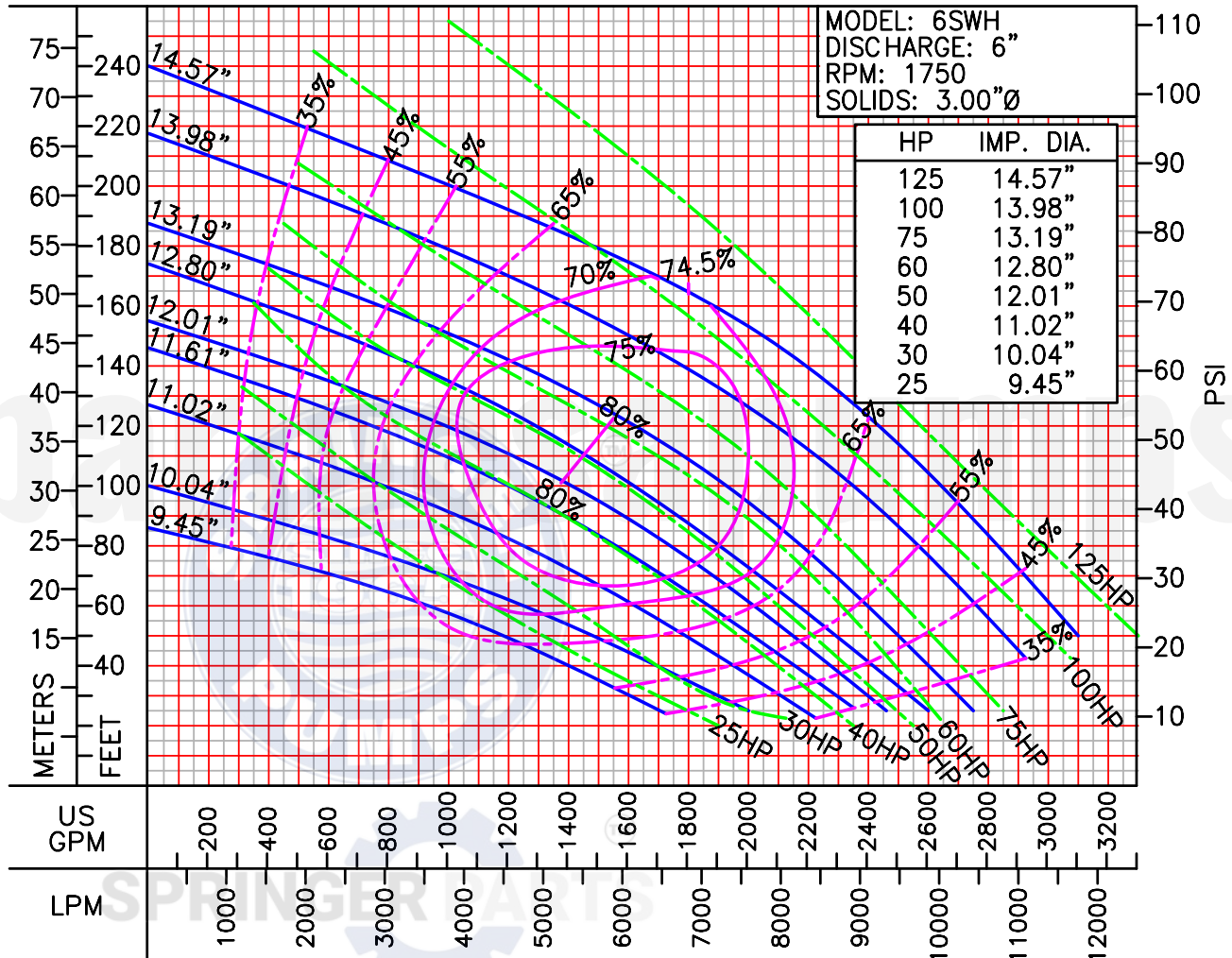

LIQUID: WATER
SPECIFIC GRAVITY: 1.00

TEMPERATURE: 70° F (21° C)
MAXIMUM DIA. SOLIDS: 3.00"Ø

PERFORMANCE CURVES

Submersible Solids

Handling Pumps

Series: **6SWH-DS @ 1150 RPM**

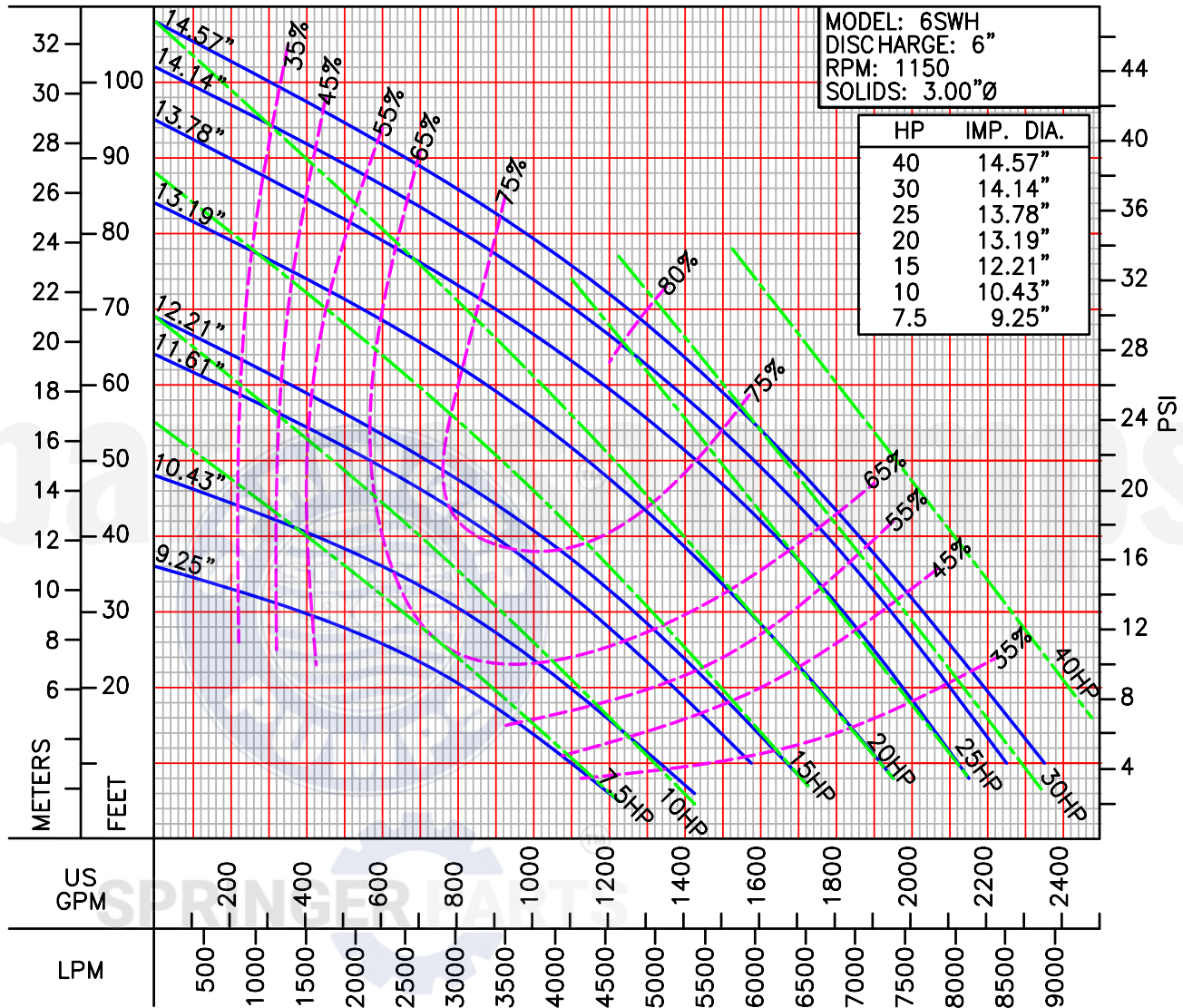

LIQUID: WATER
SPECIFIC GRAVITY: 1.00

TEMPERATURE: 70° F (21° C)
MAXIMUM DIA. SOLIDS: 3.00"Ø